

## CONCRETE DRIVEWAY

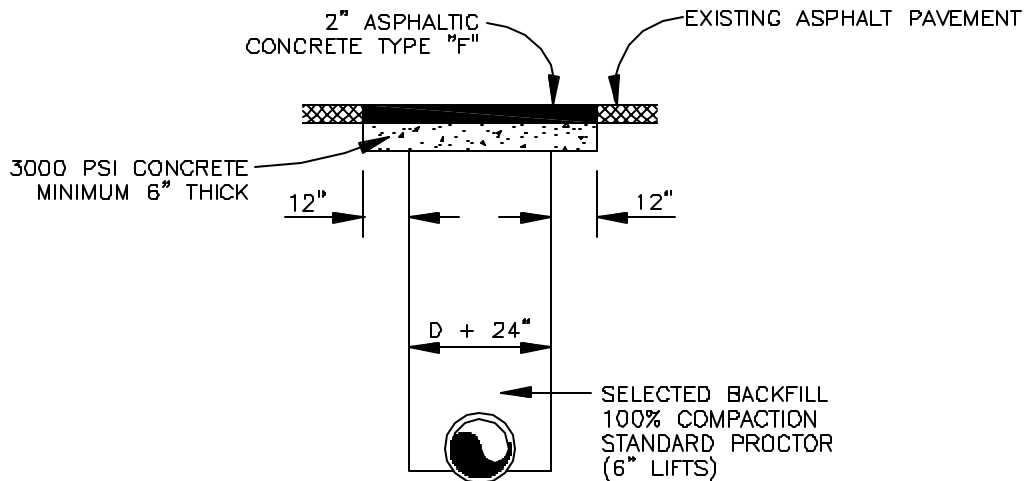

## ASPHALT DRIVEWAY

**NOTES:**

1. BACKFILL TO BE COMPACTED AS DIRECTED IN SPECIFICATIONS.
2. D = NOMINAL PIPE DIAMETER

**CHEROKEE COUNTY  
WATER & SEWERAGE  
AUTHORITY**

**TYPICAL  
DRIVEWAY  
CUT REPAIR  
CONSTRUCTION STANDARD**

DATE: FEB. '03

APPROVED:

STANDARD  
NO.  
**S725**