

CONCRETE DRIVEWAY

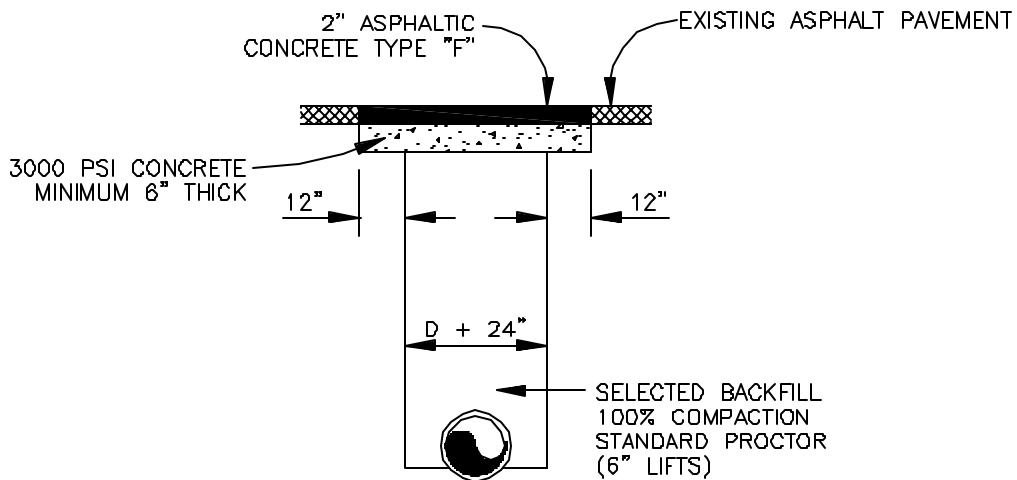

ASPHALT DRIVEWAY

NOTES:

1. BACKFILL TO BE COMPACTED AS DIRECTED IN SPECIFICATIONS.
2. D = NOMINAL PIPE DIAMETER

**CHEROKEE COUNTY
WATER & SEWERAGE
AUTHORITY**

**TYPICAL
DRIVEWAY
CUT REPAIR**
CONSTRUCTION STANDARD

DATE:	FEB. '03
APPROVED:	

STANDARD
NO.
W722